

AUTOMATIC VERTICAL COIL TONG

DATA SHEET

DESCRIPTION OF OPERATION

The automatic vertical coil tong (VCT) is designed to lift coils in a vertical (eye-to-sky) position. The tongs are robustly engineered for heavy duty application to meet the severe demands of steel- and aluminium rolling mills. The crane operator controls the entire lifting process from the crane cabin, by placing the cone into the centre of the coil. By raising the tong, the cone and the outer gripping shoe clamp the coil automatically. The suspension assembly is designed to accommodate standard crane hooks. The suspension is fixed by pull pins. Customized suspensions on request.



FEATURES

- Operated entirely from the crane cab without the assistance
- Easy access to gripping pads and grease points for all bearings
- All tongs are individually designed and calculated
- Manufactured in accordance with worldwide recognised norms (e.g. EN, ISO) and safety standards

CUSTOMER BENEFITS

- No assistance of personnel on the floor required
- Increased operational safety
- Quick handling time
- Easy to maintain and exchange of wear parts
- Minimum inherent weight
- Long working life
- Produced in line with the latest international machine guidelines

AVAILABLE OPTIONS

- Suspension custom-made
- Suspension for free hook leading - no floor personnel required.
- Anti-scuffing device with wear plates
- Adjustable outer gripping shoe
- Special gripping shoe for thin sheets
- Extended inner cone

AUTOMATIC VERTICAL COIL TONG

PRODUCT INFORMATION

TYPICAL COIL SPECIFICATIONS *

Inside diameter	from 460 mm to	850 mm
Outside diameter	up to	2'800 mm
Width	up to	2'300 mm
Temperature of coil	up to	350°C
Weight of coil	up to	50 t

*) Tongs for all coil dimensions are available according to customer requirements.

EXAMPLE DRAWING

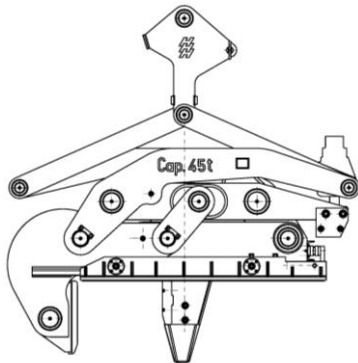

Heppenstall vertical coil tongs are designed to accommodate custom coils of all dimensions.

SAMPLE PICTURE



Other VCT's available:

- Automatic vertical coil tong – double grip type
- Motorized vertical coil tong – gripping through the bore – « Reprise Feuillards »

All lifting equipment complies with the latest machine guidelines and the new EU/EN standards. Heppenstall use material of high quality and ultrasonic tested steel plates according EN10204 for safety-related components.