

HORIZONTAL COIL TONG MOTORIZED SINGLE/DOUBLE TYPE

DATA SHEET

DESCRIPTION OF OPERATION

The motorized horizontal coil tong (HCT) single/double type is designed to lift coils in a horizontal position. The tongs are robustly engineered for heavy duty application to meet the severe demands of steel mills. The crane operator controls the entire lifting process from the crane cabin. The tong is operated by a three-phase gear motor and rack and pinion transmission. The electric circuit is wired into a terminal box on the tong. The suspension assembly is designed to accommodate standard crane hooks. The standard suspension is fixed by pull pins. Customized suspensions on request.

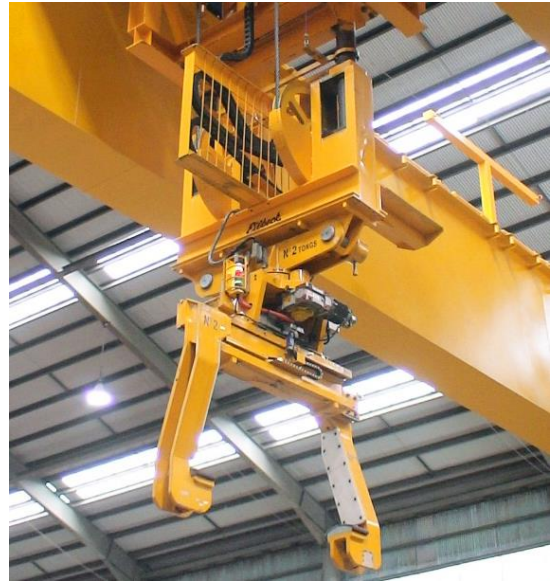

FEATURES

- Operated entirely from the crane cab without the assistance
- Easy access to gripping pads and grease points for all bearings
- All tongs are individually designed and calculated
- Manufactured in accordance with worldwide recognised norms (e.g. EN, ISO) and safety standards

CUSTOMER BENEFITS

- No assistance of personnel on the floor required
- Increased operational safety
- Quick handling time
- Easy to maintain and exchange of wear parts
- Minimum inherent weight
- Long working life
- State-of-the-art product according to latest international machine guidelines

AVAILABLE OPTIONS

- Rotating unit
- Electrical provisions for fully-automatic lifting process - radio control for the tong
- Load presence indicator switch in lifting shoes
- Lateral mechanical limit switch with control lamp
- Lateral limit switch by photo cells
- Through beam sensor for coil bore detection
- Absolut encoder for detection position of arms
- Coil protection by anti-scuffing device
- Motorized retractable tong shoes

HORIZONTAL COIL TONG MOTORIZED SINGLE/DOUBLE TYPE

PRODUCT INFORMATION

TYPICAL COIL SPECIFICATIONS *

Inside diameter	from 508 mm to	762 mm
Outside diameter	up to	2'200 mm
Width	up to	2'800 mm
Temperature of coil	up to	500°C
Condition of coil		dry or oiled
Weight of coil	up to	50 t

*) Tongs for all coil dimensions are available according to customer requirements.

EXAMPLE DRAWING

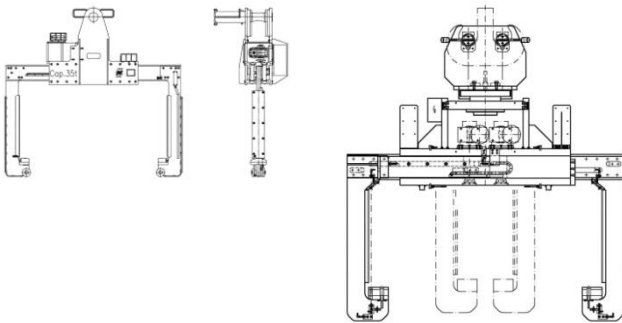

Heppenstall horizontal coil tongs are designed to accommodate custom coils of all dimensions with or without rotating unit.

3D VIEW



Other HCT's available:

- Horizontal coil tong automatic
- Horizontal coil tong hydraulic parallel linkage type
- Horizontal coil tong motorized parallel linkage type
- Horizontal coil tong for palette with safety device
- Horizontal coil tong rack & pinion type for hot coils

All lifting equipment complies with the latest machine guidelines and the new EU/EN standards. Heppenstall use material of high quality and ultrasonic tested steel plates according EN10204 for safety-related components.